



# **AC or DC MODELS**

## **USERS MANUAL**

---

### **Table of Contents**

<b>SECTION</b>	<b>TITLE</b>	<b>PAGE</b>
<b>I.</b>	<b>Introduction</b>	<b>2</b>
<b>II.</b>	<b>General Specifications</b>	<b>3</b>
<b>III.</b>	<b>Installation of Panel Mount</b>	<b>4</b>
<b>IV.</b>	<b>Panel Mount Diagram</b>	<b>5</b>
<b>V.</b>	<b>Operating Instructions</b>	<b>6</b>
<b>VI.</b>	<b>Water Quality Testing</b>	<b>7</b>
<b>VII.</b>	<b>Maintenance and Cleaning</b>	<b>8, 9</b>
<b>VIII.</b>	<b>Trouble-Shooting Guide</b>	<b>10, 11</b>
<b>IX.</b>	<b>Self-Contained Installation</b>	<b>11 - 13</b>
<b>X.</b>	<b>Self-Contained Diagram</b>	<b>13</b>
<b>XI.</b>	<b>Installation and Operation of Freshwater Flush</b>	<b>14</b>
<b>XII.</b>	<b>Tips for Operation of Marine Desalinators</b>	<b>15</b>
<b>XIII.</b>	<b>Membrane Housing End Cap Installation</b>	<b>16</b>
<b>XIV.</b>	<b>DC Electrical Diagram</b>	<b>17</b>
	<b>Warranty</b>	<b>18</b>

---

## ***I. SK Watermakers Introduction***

---

**CONGRATULATIONS!**

***YOU HAVE JUST PURCHASED THE MOST TROUBLE-FREE, ECONOMICAL  
MARINE DESALINATOR AVAILABLE!!!***

*All of our units are manufactured using the highest quality components and utilizing the latest technologies available in the industry today. SK's innovative engineering has changed the conception of marine desalinators from an expensive, maintenance-prone product of choice, to an affordable and reliable necessity for all types of watercraft.*

*We understand the importance of each and every watermaker. We manufacture and design all of our units to be simple, reliable and easy to maintain. We currently have desalinators operating in extreme conditions from the freezing arctic waters of Antarctica to the warm humid climates of the Amazon.*

*Marine desalinators from SK Watermakers are reliable and easy to install, but the greatest advantage of purchasing a unit from us is affordability.*

---

## II. General Product Specifications

---

### DESCRIPTION

---

<b>Membrane Housings:</b>	Fiberglass/aluminum (Lifetime Warranty)
<b>Membranes:</b>	Thin composite R.O. membranes

### TEST CONDITIONS

---

<b>Temperature:</b>	78° F (25° C)
<b>Operating Pressure:</b>	800 PSI. 900 PSI MAX
<b>Feed Water Quality:</b>	32,000 PPM Total Dissolved Solids (32.0K mg/L)
<b>Salt Rejection Performance:</b>	99.2% Rejection NaCl (Typical)

### AMPERAGE

---

<b>DC 150</b>	22 - 24 amps @ 12VDC
<b>AC 150</b>	5 amps @ 110VAC
<b>AC 300</b>	6 amps @ 110VAC

*Note: (larger units will vary with capacity)*

### WATER PRODUCTION CAPABILITIES

---

<b>Model</b>	<b>GPD</b>	<b>GPH</b>	<b>LPH</b>
<b>DC 150</b>	150	6 – 8	23 – 30
<b>AC 150</b>	150	6 – 8	23 – 30
<b>AC 300</b>	300	12 – 15	45 - 57

*Note: Membrane outputs can vary with salinity, temperature and age. Production output cannot be guaranteed for individual units.*

---

### III. AC/DC Panel Mount Instructions

---

#### Control Panel Location

---

Locate the panel on cabinet or bulkhead near the bilge area where the membrane and high pressure pump are to be placed. The units are furnished with 12 feet (2 - 6ft lengths) of high pressure hose. If a longer distance is required, a longer high pressure hose may be ordered. (See Diagram page 5)

#### High Pressure Pump Location

---

Locate the area where the high pressure pump is to be located. They must be located at approximately the water level or lower unless an optional feed pump (prefilter pump) is to be installed. Mount the pump in a dry location and keep the crankcase as level as possible. Secure with lag bolts or thru bolts.

#### Thru Hull and Prefilter Location

---

The prefilter should be in an area that is readily serviceable to facilitate filter changing. This should be below the waterline, and below the high pressure pump to facilitate removal of air.

#### Membrane Mounting

---

The membrane(s) may be placed anywhere between the high pressure pump and the control panel, preferably in the coolest space available (away from engine).

#### Hoses and Clamps

---

Run 1/2" clear braid (or equivalent) from salt water to prefilter. (if prefilter pump is to be used, it should be placed before the prefilter)

Run 1/2" clear braid to 1/2" hose barb on high pressure pump.

Run 1/4" high pressure hose from stainless steel fitting on high pressure pump to stainless steel fitting on membrane housing marked "**BRINE INLET**".

Run 1/4" high pressure hose from stainless steel fitting on membrane marked "**BRINE OUTLET**" to stainless steel fitting on panel.

Run 3/8" clear braid from membrane housing to "**PRODUCT WATER**" on panel.

Run 1/2" clear braid from 1/2" nylon hose barb marked "**OVERBOARD PORT**" to the thru hull fitting on hull of vessel. (it must be above the waterline)

Run 1/4" clear braid from 1/4" nylon barb on low pressure gauge on panel to 1/4" nylon barb on prefilter.

Run 3/8" clear braid to nylon hose barb on panel marked "**TANK PORT**" to top of water tank.

## IV. Panel Mount Installation

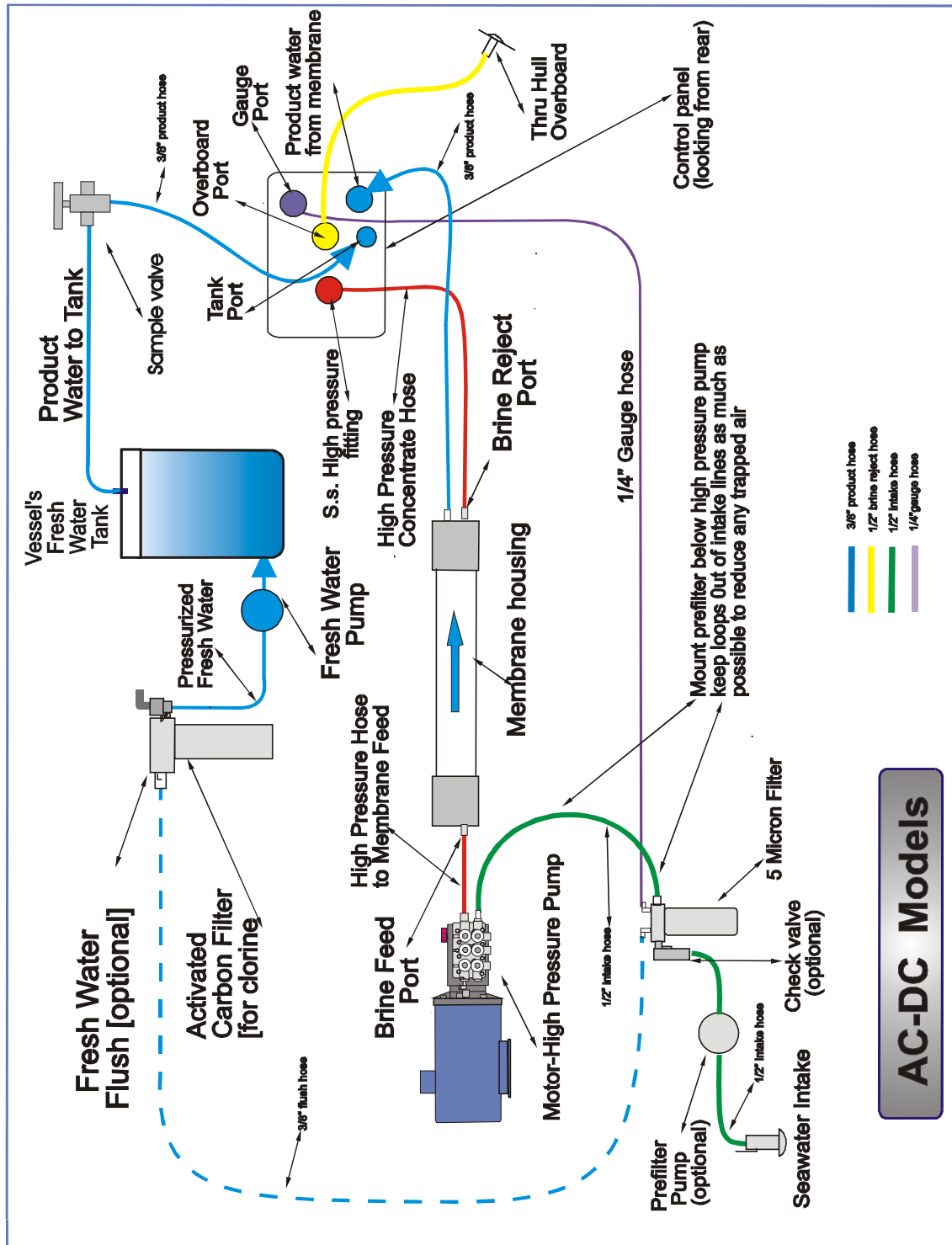

---

## V. Operating Instructions

---

### Step 1.

---

Fill 5 micron prefilter with clean seawater and prime hose from prefilter to HP pump. This normally only has to be done after installation. Check all connections for tightness and seaworthiness and open seacock.

**NOTE: The RO membrane will fare much better if they are situated in the coolest section of the engine room as you can manage to fend of biological growth.**

### Step 2.

---

Back off the high pressure valve a turn or two. Turn the power switch to "ON" position and observe pump for normal operation and check for leaks. Make sure water is flowing. If no water is moving in the system, check for an air leak in the low pressure hose fittings (with a prefilter pump this is generally not a problem). After water is flowing clear with no bubbles observed, slowly turn the high pressure valve (black knob) clockwise to 800 PSI. The adjustable automatic regulator has been preset to approximately 800 PSI at the factory.

### Step 3.

---

Run system for 1 hour and check salinity meter. If reading is under 800 you may divert the product water to the tank. The system is filled with a preservative solution and salinity or T.D.S. will improve after a short period of operation. In normal operation it is advisable to start up with no pressure for a minute or two. When stopping the RO unit, the pressure should be turned down first.

**The above steps are not necessary, but will increase the life of the unit somewhat.**

**WARNING!**

It is advisable not to use an RO unit in a highly polluted or silted harbor. If it is necessary, carefully monitor the prefilters. The pump should be shut down when low-pressure gauge reads negative 5" H

---

## **VI. Water Quality Testing**

---

The water quality produced by the RO unit upon starting will be low due to the normal osmotic pressure (salt tends to diffuse into fresh sea level). Under normal everyday use drinkable water would become available in a very short time (usually under a minute). If the units sits without use for an abnormal period, the time required to produce acceptable water will increase.

### **Poor Production/Water Quality - Symptoms Causes**

---

- Time between use (every day use would be best)
- Temperature (hot climates and engine rooms tend to increase bacterial activity)
- Seawater quality
- Salinity

### **Symptoms Reduction**

---

- Everyday use
- Fresh or permeate water flush
- Preserving (Pickling the membrane)

---

Depending on the model you purchased, your unit will be provided with a electronic tester (hand held or built in). The hand-held models will read directly in T.D.S. (total dissolved solids) which will be salt content in parts per million.

The world health organization recommends approximately 800 PPM as a limit, but if your unit has increased to 700 or higher, we recommend you clean or replace your membrane. Also for an accurate reading, let the RO unit run for 10-15 minutes before sampling. This does not have to be done every day, but would be a good addition to your maintenance schedule every two weeks or so.

---

## VII. Maintenance and Cleaning

---

### Short Duration Shut Down Procedure - (less than 2 weeks)

---

*If you purchased a **fresh water flush** with system see section on fresh water flush operation instead of this section*

- Connect a 1/4" hose to product water sample port
- Place the other end of hose in clean 5 gal bucket
- Fill 5 gallon bucket with RO water before continuing
- Turn high-pressure control valve counter-clockwise to fully open position
- Run system for 5 minutes to flush membranes
- Shut system off!!
- Connect 1/2" hose to pump intake port
- Stick the other end of 1/2" hose into 5 gal bucket of RO water
- Make sure unit is primed
- Run unit until almost all of the water has been sucked out of the 5 gal bucket
- Shut system off!!
- **DO NOT LET BUCKET EMPTY COMPLETELY-TO KEEP AIR OUT OF**

### MEMBRANE

**WARNING!!!**

**DO NOT LET THE PUMP SUCK AIR-LEAVE SOME WATER IN BUCKET**  
**Do not use water from on board tanks. Chlorine may have been used in the tanks.**

**Chlorine will permanently damage the RO membranes.**

### Long Duration Shut Down Procedure - (more than 2 weeks)

---

- 1.) Collect (2) 5 gallon containers of RO water if unit does not have a flush, only (1) is needed if it has a flush. This water can also be pure fresh water with no chlorine or ozone.
- 2.) Turn high pressure control all the way counterclockwise (lowest pressure) and place sample valve in sample position and flush for 10 minutes if unit has a flush.
- 3.) If unit does not have a flush system: (a) turn intake valve on left to pickling position. (no. 2) Leave valve on right in normal overboard position. (b) place short hoses on pickling valves long enough to reach bottom of 5 gallon container. Place 3/4" or left hose in the container, turn RO on until water is almost empty (do not run dry), this will flush most of the seawater from the system.
- 4.) Now place the right-hand valve in the pickling position, both valves should have the arrow pointing towards the center. (see diagram on P.13) Pour the container of pickling material in the 5 gallon bucket of water previously made in step 1. Make sure high pressure valve is turned all the way down and start RO, the pickling solution will then be drawn into the system and back out the reject valve to the bucket, circulating in a closed loop. Run for approximately for 30 minutes.
- 5.) Turn valves back to the original position.

*When resuming normal operation. Start system and let it run for 30 minutes at normal operating pressure and divert product water. Check product water with*

*the salinity meter provided. If within operating limits you can now send product water back to tank.*

---

## **VII. Maintenance and Cleaning (cont.)**

---

### **Pump Maintenance**

---

Change pump seals on Cat Pumps after 2000 hours of use, or when leakage occurs. All pumps need oil changes every 500 hours, after the initial 50 hour oil change.

### **Prefilters**

---

Observe prefilter gauge pressure. This will give you a good indication of your prefilter's condition. If pressure falls below 5 inches of mercury it is time to change your prefilter and clean intake strainer (plankton filter - if one is in line). Normal reading will be above 0 PSI with addition of optional prefilter pump.

### **Control Housing**

---

Check fittings for leaks, clean housing with plain soap and water. Check high-pressure pump for leaks at fittings.

### **Membrane**

---

If production falls and TDS goes above 700 PPM the membrane may need to be cleaned. If production does not come up after cleaning, repeat procedure. If the cleaning procedure is not successful, the membrane will need to be replaced.

### **Membrane Cleaning Procedure**

---

Follow the Long duration Shut Down Procedure detailed previously but instead of using 1/3 lb. preservative, dissolve (1/3 lb.) Alkaline Membrane Cleaner into you 5 gallons of water. Cleaner should be at 95 to 110 degrees for proper cleaning. Discard contents of container and change cleaning valves to normal position and run for 30 minutes at lowest pressure. (high pressure regulator valve turned all the way counterclockwise). Return to normal operating pressure and discard product water for 30 minutes.

### **WARNING!!!**

**Use of any cleaning or pickling cartridges or chemicals not specifically recommended by SK will void your warranty on ALL SK Watermakers equipment.**

## VIII. Trouble-Shooting Guide

CONDITION	CAUSES	REMEDY
<b>High negative reading on prefilter gauge</b>	Clogged water inlet	Check for stoppage
	Stopped up or kinked hose from inlet	Remove debris or replace hose
	Dirty prefilter or strainer	Clean strainer or change filters
<b>High pressure gauge will not come up to 800 PSI</b>	No intake water	Check prefilter and vacuum gauge; check intake; replace filters if necessary
<b>High pressure pump runs rough</b>	Air in inlet plumbing	Tighten connections; check for proper location of through hull
	Restrictions in inlet plumbing	Check for kinks or dirty prefilters
	Defective valve or seals in HP pump	Repair or replace pump
<b>Low product water</b>	Fouled or worn RO membrane	Clean or replace RO membrane
<b>High product water flow</b>	Failed RO membrane	Replace membrane
<b>High Pressure pump does not run</b>	Using RO unit in fresh or brackish water with pressure set too high	Lower pressure
	Defective electric motor	Repair or replace motor
<b>Product water quality above 800ppm</b>	Defective breaker, switch, or fuse	Repair or replace breaker, switch or fuse
	Fouled RO membrane	Clean or replace RO membrane

---

## **IX. Installation Instructions of AC/DC Self-Contained Units**

---

### **Select a seawater supply**

---

A pressure system such as an air-conditioning pump is an excellent source. If one is not available, you will have to install a new thru hull and seacock. 3/4" I.D minimum. The thru hull must be positioned as close to the bottom center of the boat as possible. Make sure there is nothing in the slip stream in front of the intake, or if in a sailboat, the thru hull is as low as possible so that the thru hull will not be above the waterline at a large heel angle. It is advisable to install an intake strainer at this time. It would also be advantageous to keep the intake ahead of the prop wash. (air bubbles are a high pressure pump's greatest enemy!!!) An optional feed pump is an excellent supply for the high pressure pump, but if the high pressure is kept at no more that 2 feet above the water level, the desalinator will operate satisfactory without a pressure feed.

### **Select a location for the prefilter bank**

---

The prefilter bank should be between the thru hull and the high pressure pump, in a location that is accessible. (clean prefilters are very important to the operation of the entire unit)

### **Select an area for the RO unit**

---

The RO housing should be kept in as cool a place in the bilge as possible. It may be installed under a bunk or in a vee birth. The prefilter would be of course be mounted in the bilge to facilitate servicing filters. (see Diagram 1)

### **Select another 1/2" thru hull for the brine overboard dump**

---

It should be located above the waterline. Location is not critical and you may use a sink drain if installed properly.

### **Seacock/Prefilter Manifold Connection**

---

Connect the brine dump manifold to an overboard fitting with a 1/2" hose. Connect prefilter to the seacock with 1/2" reinforced beverage hose. IMPORTANT!! Use a very shallow radius from the pump intake to the prefilter to help reduce cavitation

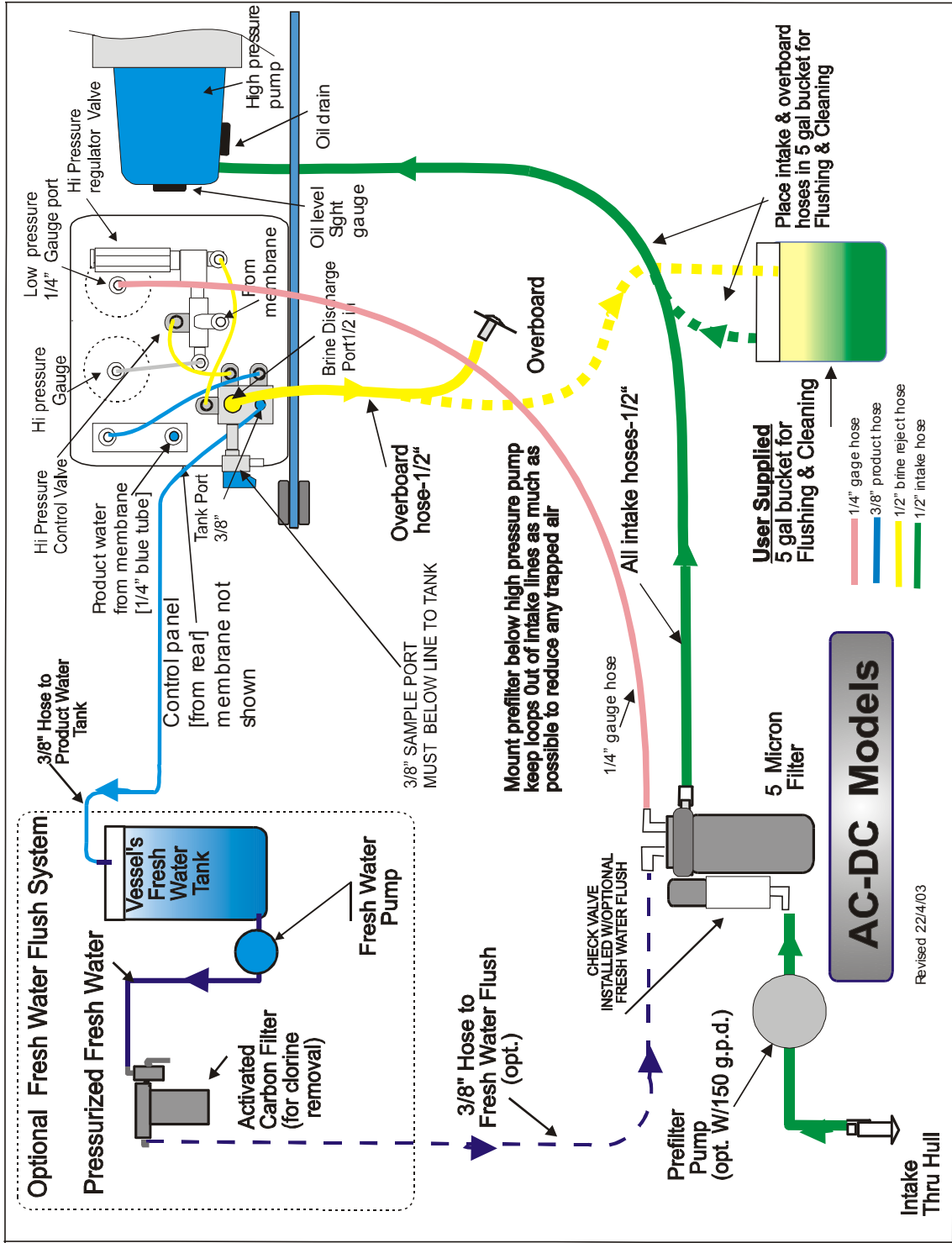

---

## **IX. Installation Instructions of AC/DC Self-Contained Units (cont.)**

---

### **Fresh water connection**

---

Connect the freshwater to the top of the tank with 1/4" soft tubing. This should not have a shut off in this line. A stoppage of the product water will damage the unit. It should be run high enough above the tank so that any tank water will not siphon back to the RO unit.

### **Wiring - 12V DC**

---

Run marine boat cable to junction box or switch from DC source. #8 gauge wire is adequate. Use #6 gauge wire over 20 ft. The wire should be fused at 30 amps.

### **Wiring - 120V/240V**

---

#14 gauge marine boat cable w/ground is recommended. AC breaker size should be 10-15 amps.

---

## **XI. Installation and Operation of Fresh water Flush (Optional)**

---

### **Installation**

---

- Locate convenient location and install flush
- Run 3/8" hose or line to pressurized water from ship's freshwater system supply
- Run 3/8" hose from freshwater flush to 3/8" barb on prefilter (if installed by owner run hose from flush to tee installed as shown in install diagram (see Drawing 5)

### **Operation**

---

- RO unit should be OFF while flushing
- High pressure valve on control should be in the open position (all the way counterclockwise)
- Turn Blue handle on the freshwater flush so the handle is inline with the valve and let it flush for 5 to 10 minutes
- Close valve on fresh water flush filter - flushing is complete
- Flushing is very good insurance against membrane failure and will increase the life of your entire system
- Flushing may be done at any time after RO shutdown with a simple turn of the valve on the carbon filter
- A good practice would be to flush your RO after every use, if it is not to be used every day

The activated carbon filter must be changed at a maximum of 12 months regardless of use. Use a high quality filter as any chlorine will damage the RO membrane.

---

## **XII. Tips for Operation of Marine Desalinators**

---

### **THE DO'S**

---

- Lower pressure before stopping and starting.
- Lower pressure in brackish water. (Stay within the GPH rating of the unit)
- Flush RO unit with fresh water whenever possible. **(NO CHLORINE)** A freshwater is available at a low cost.
- Preserve RO membrane with pickling solution for long time storage. (up to 6 months)
- Monitor prefilters carefully for blockage. (a prefilter pump will extend their life many times)
- Change oil in high pressure pump. (check pump recommendations)

### **THE DON'TS**

---

- Operate in very silty conditions. (this may scale membranes and require acid cleaning)
- Operate in any situation with oil in the seawater.
- Let the RO membrane(s) dry out, they will be irreversibly damaged.
- Share a thru hull with any other devices aboard. **(EXCEPTION!!!** Saltwater wash down pump)
- Operate under low voltage conditions.
- Clean equipment with anything but soap and water or alcohol. (no acetone)

### XIII. Membrane Endcap Installation

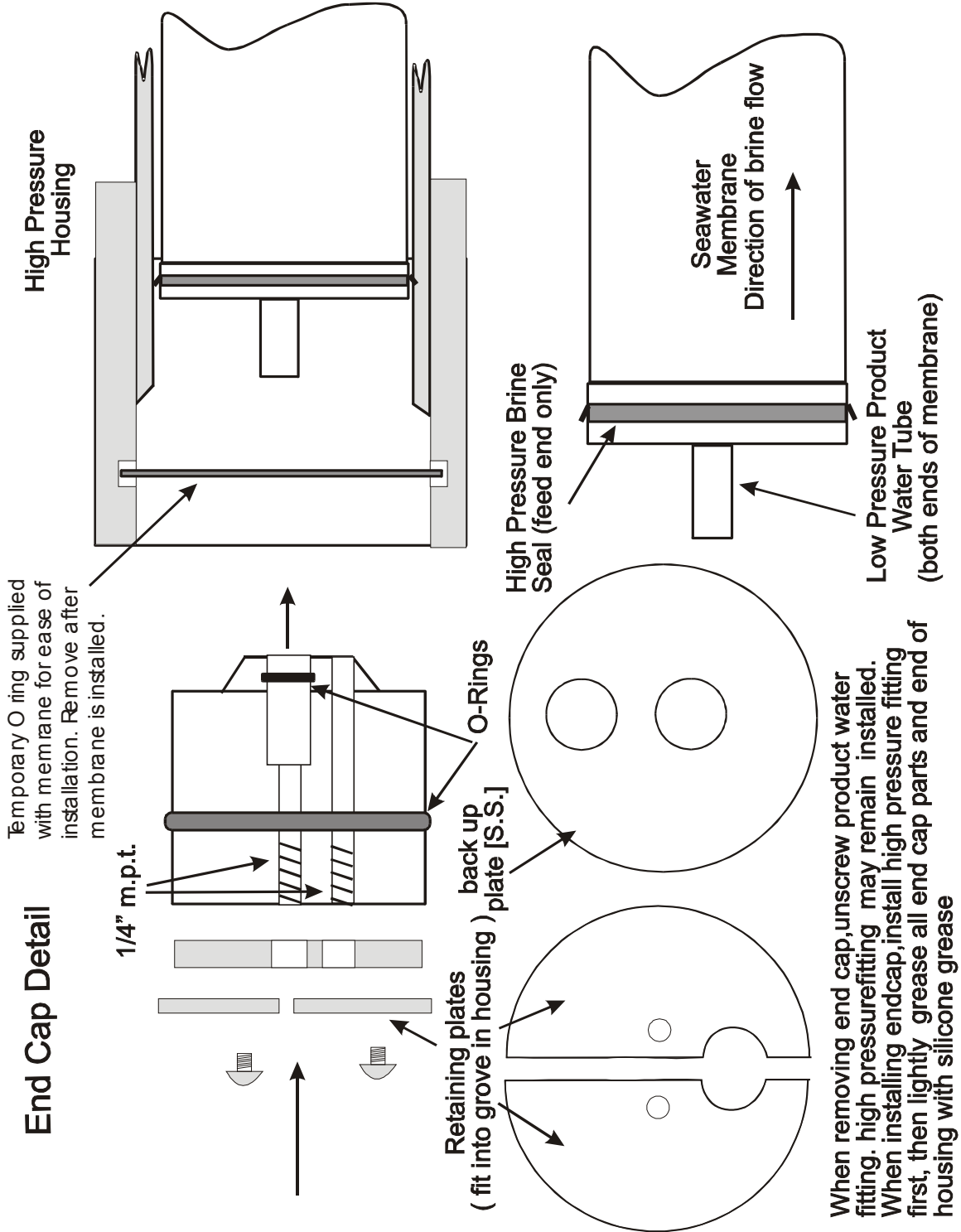

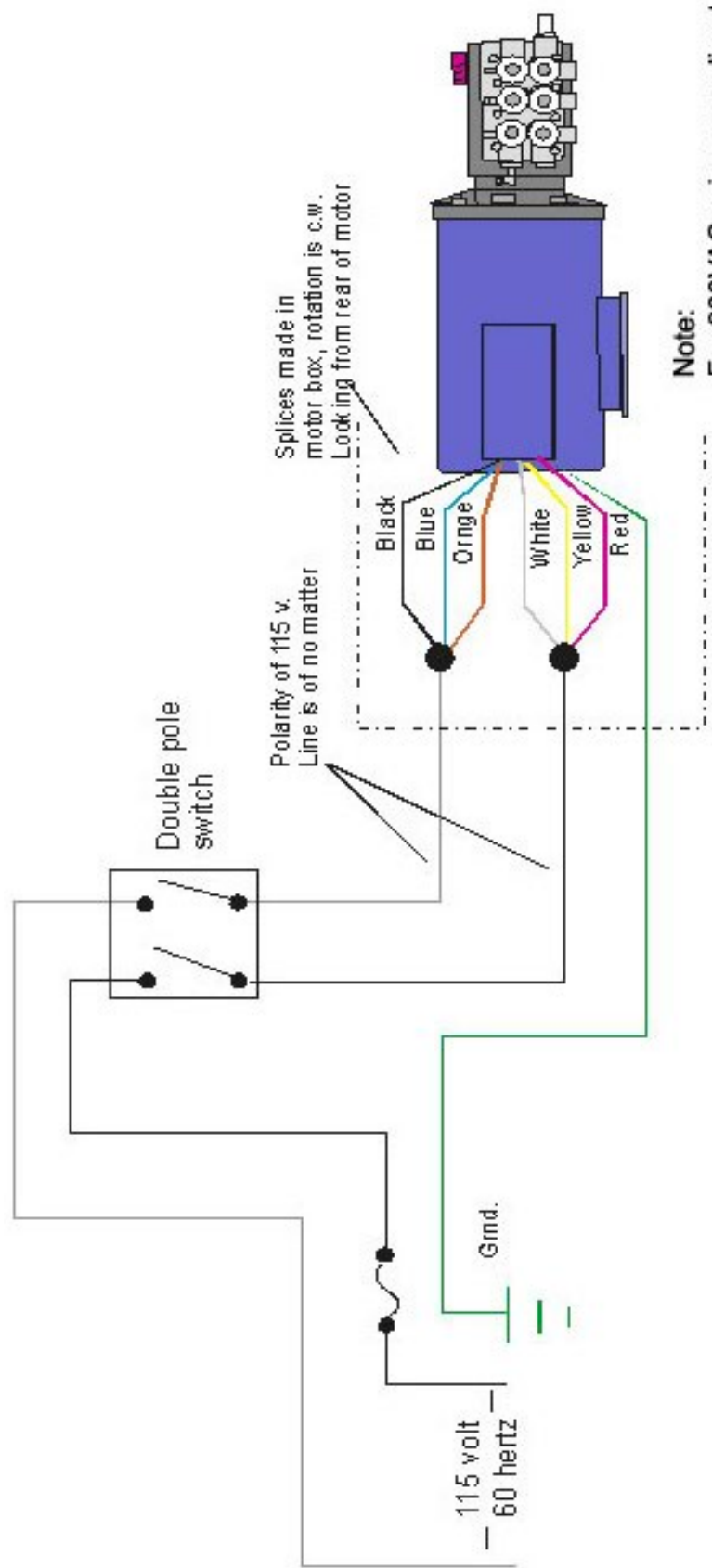

**Note:**  
For 230VAC, wire according to motor wiring diagram.

## 115 VOLT A.C. UNITS

## LIMITED WARRANTY

SK Watermakers (from herein called SKW) warrants each new reverse osmosis unit/system to be free from defects in materials and workmanship under normal use, if installed and operated under SKW's design specifications, under the conditions listed below.

HARDWARE LIMITED WARRANTY: For a period of 1 year from initial use, SKW will repair and replace, at its option, any part of the HARDWARE which we find to be defective due to faulty materials or workmanship. Shipping charges shall be the responsibility of the purchaser.

This warranty shall only cover the original purchaser. Any damage caused by alteration, physical damage, installation, or operation contrary to our written specifications or instructions are not covered by this warranty.

IN ADDITION: it is the responsibility of the owner/user to change crankcase oil in pumps every 500 hours after the initial 50 hour oil change, also change prefilters as advised in the manual and furnish an AIR FREE supply of feedwater to the unit. Failure to comply or evidence of failure to comply with these requirements shall also void this warranty.